

Z1



SPECIFICATION SHEET

LACQUERED BACK PANELS

Straight structural back panels made of 30mm lacquered melamine faced chipboard (MFC) finished with 2mm impact resistant ABS edges in a matching matt lacquer finish. MFC density 670/730 kgs per cubic meter. Fittings provided.

Corner structural back panels made of 30mm lacquered melamine faced chipboard (MFC) finished with impact resistant ABS edges in a matching matt lacquer finish. MFC density 670/730 kgs per cubic meter. Straight and corner back panels are 45 degree mitre cut and joined together to form a 90 degree angle using fittings provided.

LACQUERED WORKTOPS

Made of 30mm lacquered melamine faced chipboard (MFC) finished with 2mm impact resistant ABS edges in a matching matt lacquer finish. Corner worktops are 45 degree mitre cut and joined to corner back panels to form a 90 degree angle using provided fittings. Straight worktops are joined to straight back panels using brackets provided. MFC density 670/730 kgs per cubic meter.

LACQUERED COUNTER MODULE

Made of 18mm and 30mm lacquered melamine faced chipboard (MFC) finished with 1.5mm and 2mm impact resistant ABS edges in a matching matt lacquer finish. A counter module is formed of 45 degree mitre cut panels joined together to form 90 degree angles using fittings provided. MFC density 670/730 kgs per cubic meter.

Finish options:

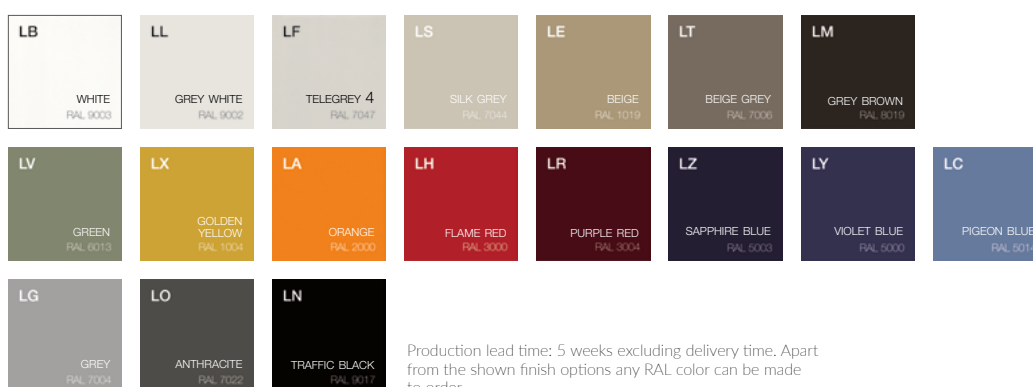

METAL PARTS

Tubular support leg made of 50x50mm 1.5mm steel tube with a 2mm steel support plate. Leg and plate are supplied powder coated. Outer metal plinth supplied as standard, made from 6060 extruded anodized aluminium fitted to the back panels using clips provided.

Finish options:



LIGHTING (OPTIONAL EXTRA)

Optional flexible cool white LED strip, can be bent or cut without compromising on functionality. Easy peel-and-stick backing mounts to the lower end of plinths. Includes an ON/OFF switch.

Optional flexible cool white LED strip set within a 6060 extruded anodized aluminium profile covered with translucent anti-glare polycarbonate. Mounts to the lower end of counter modules.

24V LED power supply. 2mtrs long power cable. Fixed using self-tapping screws to the inner face of the straight and corner structural modules.



Z1 RECEPTION WITH ENDING LOW COUNTER

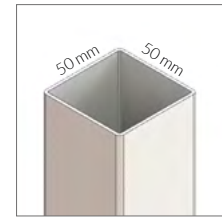
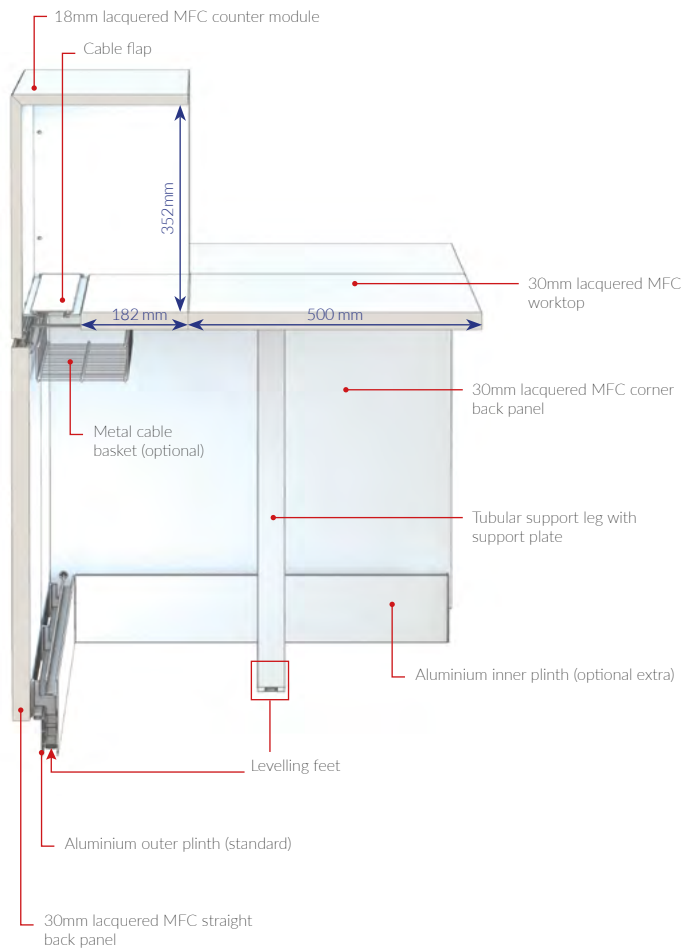

Tubular support leg made from 50x50mm 1.5mm thick steel tube supplied with 3mm steel support plate.

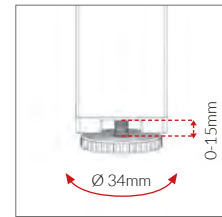

Levelling feet for middle leg, Ø 34mm, 0-15mm travel.

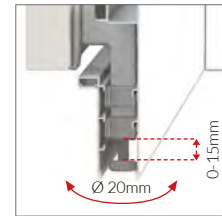

Polyethylene levelling feet, Ø 20 mm, 0-15mm travel.

LAYOUT

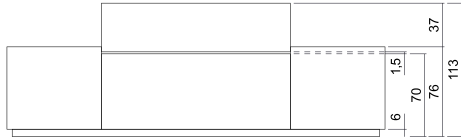

SYMMETRICAL CONFIGURATIONS

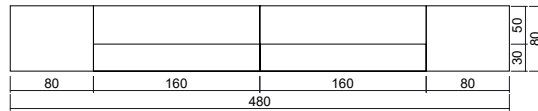
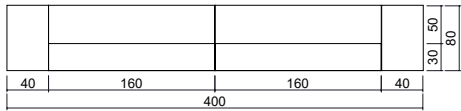
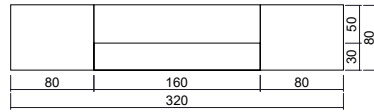
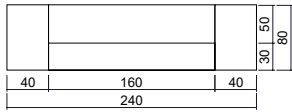

ASYMMETRICAL CONFIGURATIONS

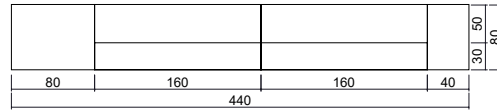
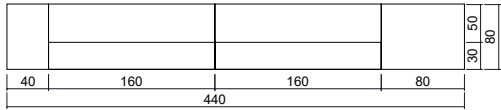
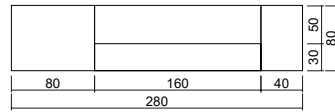
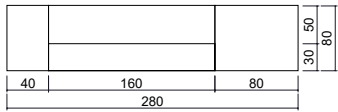

ACCESSORIES

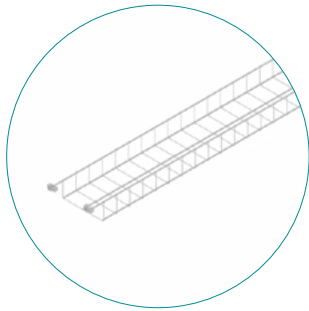

Metal cable basket



Translucent Abs cable spine



Peel-and-stick translucent polycarbonate cable riser

SUSTAINABILITY & CERTIFICATIONS



MATERIALS AND RECYCLABILITY

Panels used on Z1 range are exclusively 100% made by recycled wood and respect low formaldehyde emission (CATAS certification Quality Award Formaldehyde E0). Resins used on panels and melamine paper are SVHC substances free (reported on ECHA list update to 12/01/2017)



CERTIFICATES

Constantly receptive to market requirements, Quadrifoglio Group pay special attention on quality and safety contents in order to provide high products and services. The Company has reached certifications UNI EN ISO 9001/2008, UNI EN ISO 14001/2004 and BS OHSAS 18001/2007 to confirm his policy. Our products are certified and ensured by FSC™ and ECOLOGICAL PANEL.

COMPANY WITH
MANAGEMENT SYSTEM
CERTIFIED BY DNV GL
= ISO 9001 =
= ISO 14001 =
= OHSAS 18001 =



GREEN ENERGY

The Company had installed the photovoltaic system with 4,500 solar panels in a 7.350 m² surface that covers almost entirely the factory. The photovoltaic is able to produce 1Mw of a quiet green energy, that does not harm the environment and is waste-free. With his high production capacity the photovoltaic allows us to reduce emissions in the atmosphere of all those polluting substances and to those that contribute to the greenhouse effects. Consequently, such measures make us save every year 180 tonne of petrol oil, 440 tonne of CO₂, 514kg of sulphur dioxide, 448 kg of nitrogen oxide and 23kg of dust.



TRANSPORT

Packaging is reduced in order to decrease volumes. Goods collections are responsibly managed and organised with the aim of optimise transports, reducing atmosphere emissions.