

WINX LOUNGE



WX 885.06

Design: Kai Stania

Manufacturer: RIM CZ a.s.

WINX LOUNGE 885

Modern, fully-upholstered armchair of rounded shape with armrests, designed for relaxation zones, home offices, waiting areas, entrance halls and receptions.

Precise upholstery work allows for experimenting with colour and material combinations.

Design	<p>Two-part polyurethane shell consisting of a base part (structure) and backrest.</p> <p>The structure is comprised of a frame welded from steel wires and reinforced in the point of connection to the base. The frame is covered with PUR foam, bulk weight of 65 kg/m³.</p> <p>A polyurethane seat, foamed in a mould with a thickness of 80 mm and bulk weight of 65kg/m³, ensures comfortable sitting.</p> <p>The polyurethane foam is free of added CFC's and with reduced flammability as per California Technical Bulletin 117, Section A Part 1 and Section D Part 2.</p> <p>The armchair is available with aluminium four-star base or wooden base.</p>
Base	<p>01 – four-star aluminium base with central metal tube of Ø 50 mm in diameter. Base with plastic glide, felt pads or Teflon optional. Base surface treatment – a combination of polished aluminium and chrome steel tube or powder coating as per RAL.</p> <p>06 – wooden base is made of oak solid wood with cross-section 40/70 mm, painted with clear polyurethane lacquer.</p>
Upholstery	To be selected from fabric collection.
Warranty	5 years (see Business conditions).

Dimensions (in mm)

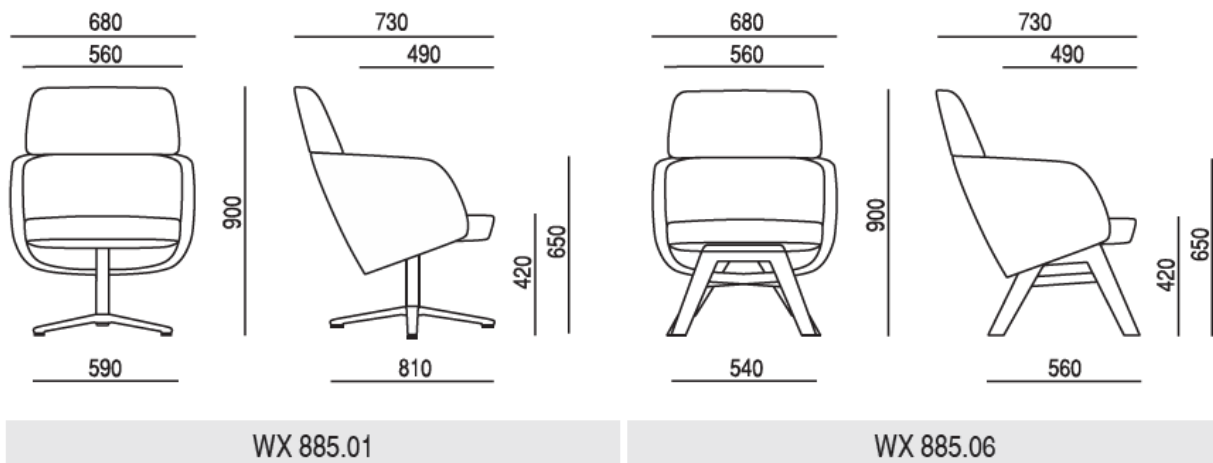

Concept WINX LOUNGE (in mm)



WX 886.01



WX 885.06

WINX LOUNGE



WX 886.06

Design: Kai Stania

Manufacturer: RIM CZ a.s.

WINX LOUNGE 886

Modern, fully-upholstered armchair of rounded shape with armrests, designed for relaxation zones, home offices, waiting areas, entrance halls and receptions.

Precise upholstery work allows for experimenting with colour and material combinations.

Design	<p>Three-part shell consisting of a base part (structure), backrest and headrest.</p> <p>The structure is comprised of a frame welded from steel wires and reinforced in the point of connection to the base. The frame is covered with PUR foam, bulk weight of 65 kg/m³.</p> <p>A polyurethane seat, foamed in a mould with a thickness of 80 mm and bulk weight of 65kg/m³, ensures comfortable sitting.</p> <p>The polyurethane foam is free of added CFC's and with reduced flammability as per California Technical Bulletin 117, Section A Part 1 and Section D Part 2.</p> <p>The armchair is available with aluminium four-star base or wooden base.</p>
Base	<p>01 – four-star aluminium base with central metal tube of Ø 50 mm in diameter. Base with plastic glide, felt pads or Teflon optional. Base surface treatment – a combination of polished aluminium and chrome steel tube or powder coating as per RAL.</p> <p>06 – wooden base is made of oak solid wood with cross-section 40/70 mm, painted with clear polyurethane lacquer.</p>
Upholstery	To be selected from fabric collection.
Warranty	5 years (see Business conditions)

Dimensions (in mm)

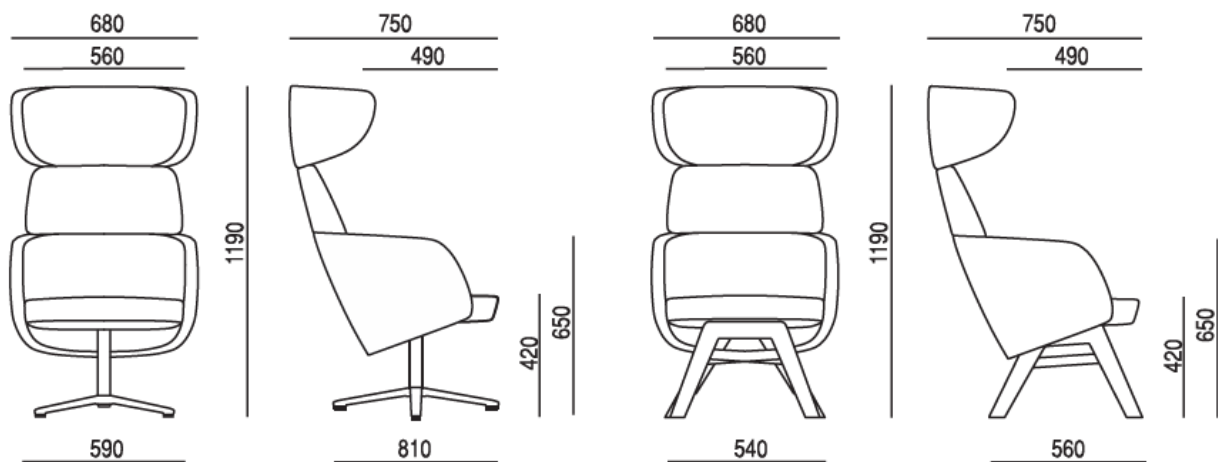

WX 886.01

WX 886.06

Concept WINX LOUNGE (in mm)



WX 885.01



WX 885.06



WX 886.01