

# Wilkhahn

Aula. 238 range.





## Aula.

When creating the Aula multipurpose chair, our designers and engineers took plastic to a new level of aesthetics and functionality. Up to 16 of the easy-care, all-plastic chairs can be stacked free-standing. Aula looks intriguingly seamless because the colors and surfaces of all the chair's parts are the same. Thanks to the precise lines and transition points of its base frame, armrests and seat shell as well as the similarity of all its components' colors and surfaces, this practical all-plastic chair has a sculptural look. The designers and engineers also wanted to come up with a perfect seat shell. As a result, its shape, elasticity and ergonomic design provide superior support and comfort for people of all shapes and sizes, even if they spend long periods of time sitting down. Viewed from the back and the sides, the organic, three-dimensional shape of the shell looks very attractive. The chair is available in white, black, gray, gray-beige and (at an extra charge) in blue-gray and orange-red on request. Choose from four types of upholstery and three types of frame, available with and without armrests, to tap into a vast number of design and functional options for congresses and multipurpose areas, company restaurants, seminar and conference centers or even co-working spaces. Depending on the frame model, integrated or optional inline connectors and practical accessories, such as stacking trolleys, seat and row numbers or writing tablets, ensure customized options for all sorts of areas.

Model 238/10, white, not upholstered, with armrests  
Design: Wolfgang C.R. Mezger





Modell 238/10. Aula is available in blue-gray, white, gray, orange-red, gray-beige and black – also in the version with a plastic frame and plastic armrests which are color-matched.





Conference setting combined with our adaptable mAx folding table range: Model 238/10, white, not upholstered, with armrests paired with mAx, 6 x 460/00 and 6 x 461/11, design Andreas Störiko.





A setting for a talk in a multipurpose space used by local government, models 238/10, gray, not upholstered, with and without armrests, photo: Robert Forster.





All ready for a dinner, with model 238/10, with and without armrests, combined with the adaptable mAx 460/00 and 461/00 table range, designed by Andreas Störiko, photo: Robert Forster.





Model 238/10, white, not upholstered, with armrests, placed in rows for training sessions and seminars and combined with the versatile mAx folding table range





Model 238/13, can be re-arranged for any type of meeting. Here, it's in black, fully upholstered, with armrests and combined with our mAx 662/00 folding table with its veneered table top and chamfered edges, designed by Andreas Störiko.





Microsoft's auditorium in Schiphol (the Netherlands). Models with plastic frames 238/10, not upholstered, 238/11 with seat cushioning and 238/12 with padding on the inside. Photo: Michael van Oosten





All ready for the next talk: Rows of seating, model 238/31, black, chrome-plated frame with seat cushioning, with armrests, linked,





Ideal for a multi-use café: Model 238/30, white, not upholstered, chrome-plated frame, with and without armrests, combined with Aline tables, white HPL, model 237/00, 140 x 70 cm (55 1/8 x 27 7/8") or model 236/2.



# Aula. 238 range. Product types.

## Wilkhahn

### Whatever the color, models with four-leg plastic frames can all be stacked

This series stands apart because the materials used for the sculptural design look so similar, so that the frame and shell appear seamless. The fully-upholstered version equally wouldn't look out of place in homes, making it a team player in today's new workspaces. Retrofittable armrests on request.



**238/10**  
Not upholstered, without armrests



**238/10**  
Not upholstered, with armrests



**238/11**  
With seat cushioning and armrests  
Mottled gray Pitch 54/24 cover



**238/12**  
With cushioning on the inside, without armrests  
Mottled gray Pitch 54/24 cover



**238/13**  
Fully upholstered, with armrests  
Mottled gray Pitch 54/24 cover



# Aula. 238 range. Product types.

# Wilkhahn

## Skid-base versions (bright chrome-plated model is stackable)

The Aula models with skid bases look exceptionally lightweight and sophisticated. Their compact frame makes the models ideal for seminar and training spaces or company restaurants. Armrests not retrofittable



**238/20**  
Not upholstered, without armrests, gray



**238/20**  
Not upholstered, with armrests, black with a chrome-plated frame



**238/21**  
With seat cushioning, without armrests, Pitch 54/13 cover – white



**238/22**  
With padding on the inside, Pitch 54/24 cover, with black armrests



**238/22**  
With padding on the inside, Pitch 54/24 cover, without armrests, gray-beige shell, chrome-plated frame



# Aula. 238 range. Product types.

# Wilkhahn

## Models with a four-leg tubular steel frame and integrated linkage option

Due to the integrated inline connectors in the four-leg tubular steel frame, Aula stands apart in multipurpose spaces and meeting areas. Because when rows of chairs are linked, the asymmetrical armrests mean center-to-center distances are very small. Armrests not retrofittable



**238/30**  
Not upholstered, without armrests, white



**238/30**  
Not upholstered, with armrests, gray with a chrome-plated frame



**238/31**  
With seat cushioning without armrest, Pitch 54/13 cover, , black



**238/32**  
With padding on the inside, Pitch 54/24 cover, with armrests, beige



**238/32**  
With padding on the inside, Pitch 54/24 cover, without armrests, white shell, chrome-plated frame



# Aula. 238 range. Product types.

# Wilkhahn

## Frame surfaces (tubular steel and round steel bar)



Bright chrome-plated or coated with a textured matte finish in black, gray, gray-beige, orange-red, blue-gray or white

## Frame and shell colors (plastic)



Black, gray, gray-beige, orange-red, blue-gray or white

## Upholstery material (not all upholstery materials apply to all types)

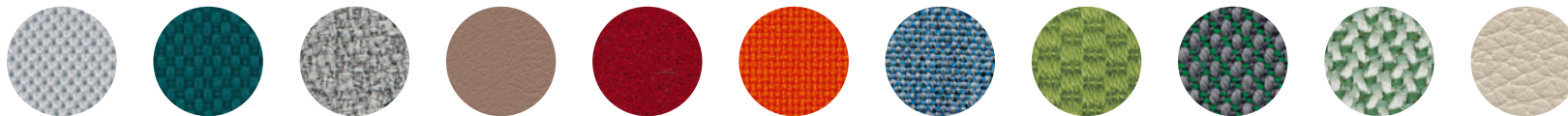

37 Racer | 47 Nova | 54 Pitch | 58 Evida | 60 Blend | 62 Bond | 63 Auris | 66 Lona | 68 Kvadrat Remix 2 | 69 Granit | 91 Kvadrat Steelcut Trio 3 | 92 Credo | 74 Leather |  
You can find all upholstery materials and more colors in our media center

The digital sample colors differ from the originals.



# Aula. 238 range. Accessories and other items.

# Wilkhahn

186 Four-wheeled trolley for up to ten Aula chairs



with a stack of chairs, model 238/10, not upholstered with a plastic frame, white

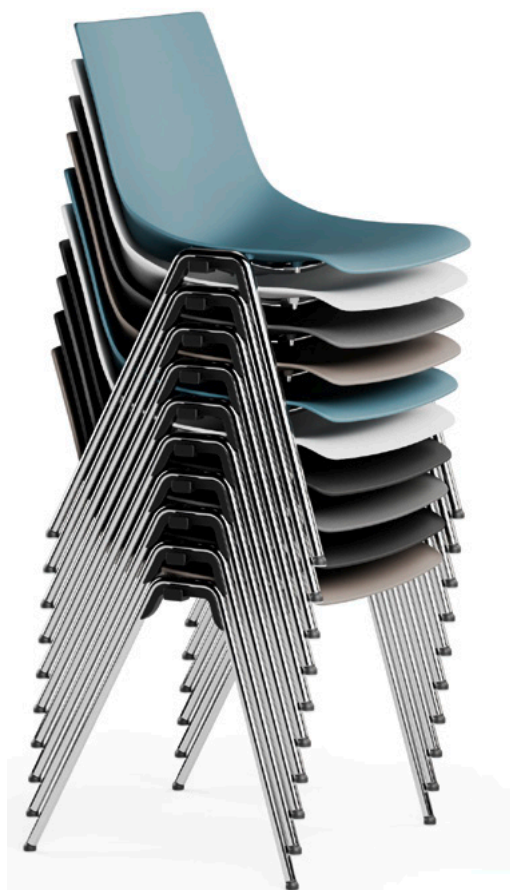

A stack of chairs, model 238/30, bright chrome-plated, not upholstered, with a four-leg tubular steel frame



A stack of chairs, model 238/20, bright chrome-plated, not upholstered with a skid base

Thanks to their A-shaped frames that come with and without armrests, up to ten of the four-leg Aula models can be stacked free-standing and vertically (height between the plastic frames when stacked: 90 mm (3<sup>5</sup>/<sub>8</sub>"'), chrome-plated tubular steel frames 55 mm (2<sup>1</sup>/<sub>8</sub>"') and up to 15 of the chrome-plated skid-base models, and up to 10 of the skid-base chairs that protrude forwards when stacked (height between chairs when stacked: 37 mm (1<sup>4</sup>/<sub>8</sub>"')).

#### Standards:

Compliant with the DIN EN 16139 office chair standard, 10 chairs can be stacked vertically (Plastic and tubular steel frame).

# Aula. 238 range. Accessories and other items.

# Wilkhahn

## Inline connectors

All Aula models can be linked up in rows, making them ideal for multipurpose spaces. In the case of versions with plastic frames, the widths and center-to-center distances vary depending on whether models without armrests, with armrests or alternately with and without armrests are connected. If it's only models without armrests that are to be linked, fixed inline connectors do the job.

If users wish to link models with armrests, without armrests or alternate between the two, the versatile, pull-out inline connectors are ideal to keep distances between the rows as small as possible. On the other hand, the widths and center-to-center distances on models with skid bases are identical because the armrests don't stick out at the sides. The same applies to the exceptionally compact models with four-leg tubular steel frames, where the inline connectors are integrated in the frame from the beginning.



### Model 191

**Fixed inline** connector to link models **with plastic frames and without armrests** (238/10, 238/11, 238/12, 238/13) made of bent steel, black zinc-plated (retrofitable).



# Wilkhahn

## Model 190

Versatile, pull-out inline connectors to link models with plastic frames (238/10, 238/11, 238/12) without armrests, with armrests or when alternating between models with and without armrests, made of bent steel, black zinc-plated, with clip made of fiberglass-reinforced polyamide in anthracite (retrofittable). Inline connectors in combination with a writing tablet on request.

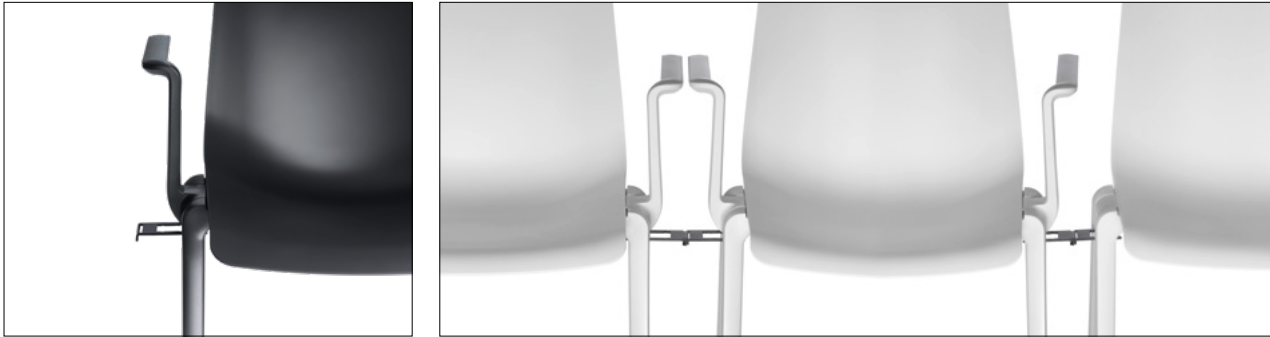

## Model 238

Inline connectors to link models with skid bases ((238/20, 238/21, 238/22), optionally without armrests, with armrests, or in combination with frames with and without armrests made of black, through-dyed polyamide, retrofittable.

Integrated inline connectors for the models with four-leg tubular steel frames (238/30, 238/31, 238/32), made of black, through-dyed, fiberglass-reinforced polyamide. Thanks to the asymmetrical layout and design of the armrests, the chairs can set up so that they are interlinked with one another and can therefore be linked in a very compact way.

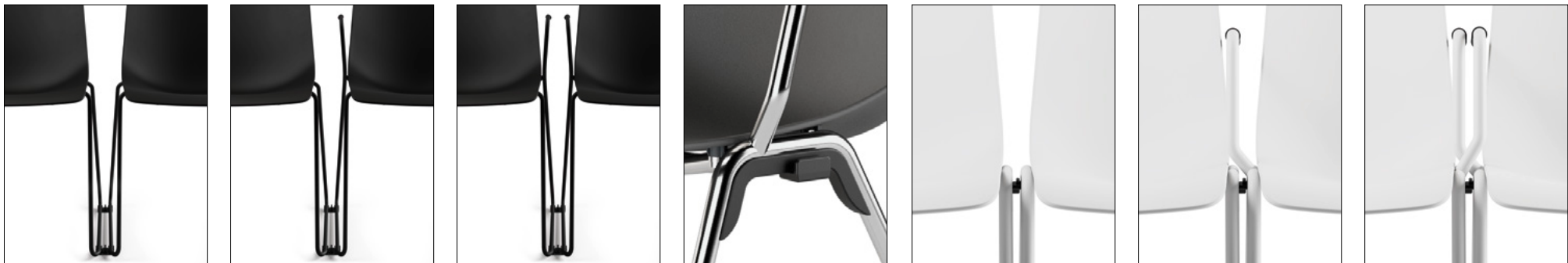

# Wilkhahn

## Numbering accessories

To number seats and rows easily and efficiently, a magnetic clip (**model 192**) is slotted onto the frame and the numbers (**model 193**) are then inserted. Please state the frame version, because the frame's diameter can vary depending on the model.

And then there's the number tag board with seat number tags from 1 to 50 (**model 193**) and row number tags from 1 to 30 (**model 194**), as well as a magnetic grip (**model 195**) so that it's easy to attach and remove the numbers. A special binder (**model 198**) for the number tag boards is the perfect way of organizing numbering systems easily.



Here with a plastic frame

## Writing tablet (only in combination with plastic frames and armrests)

Fold-up writing tablets (**model 197**) are practical options for press conferences, training courses and seminars. They can be slotted and affixed onto the armrests in no time, but the chairs can still be stacked. The writing tablets can be slotted onto the armrest on the right or left (please specify).



## Stacking trolley

All stackable Aula models (with plastic frames, bright chrome-plated metal frames) allow stacking of up to 16 when they are free-standing and up to 10 when placed on the stacking trolley (model 186).

The stacking trolley is made of black-coated steel profiles with a lateral brace and comes with four ball-bearing-mounted swivel casters with rubber coatings, two of which have a brake to lock the casters in place.





# Aula. 238 range. Models and dimensions.

# Wilkhahn

## Models 238/10 – 238/13

### 238/10 Multipurpose chair

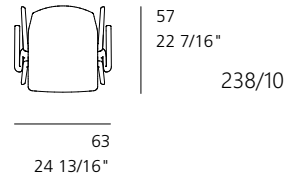
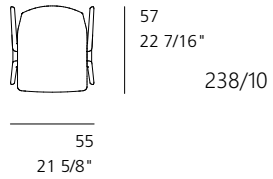
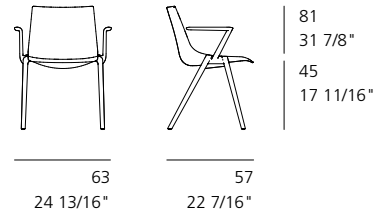
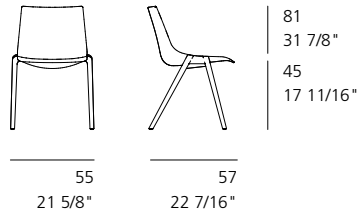
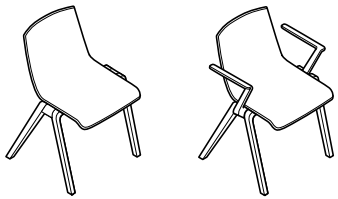

### 238/10 with 197 Fold-up writing tablet

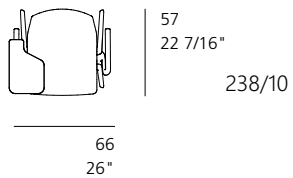
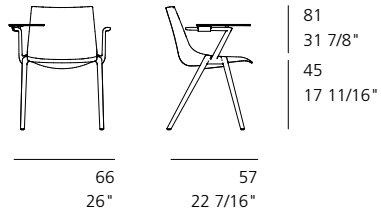

# Aula. 238 range. Models and dimensions.

# Wilkhahn

## Models 238/20 – 238/22

### 238/20

Multipurpose chair with a skid base

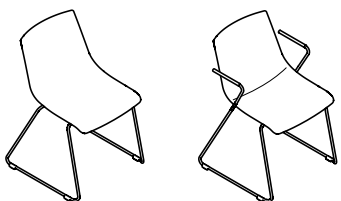

54  
21 1/4"

56  
22 1/16"

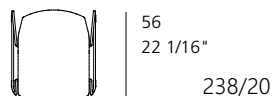

54  
21 1/4"



54  
21 1/4"

56  
22 1/16"



54  
21 1/4"



# Aula. 238 range. Models and dimensions.

# Wilkhahn

## Models 238/30 – 238/32

### 238/20

Multipurpose chair with a tubular steel frame

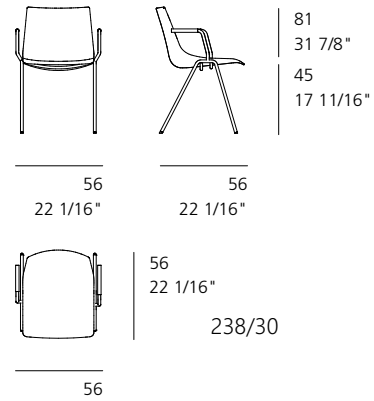
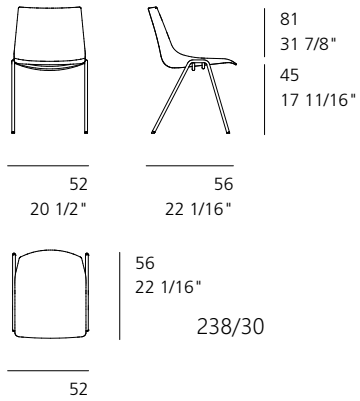
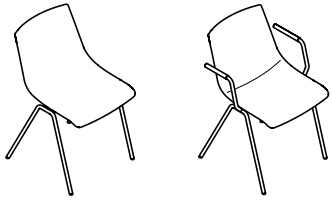

# Aula. 238 range. Models and dimensions.

# Wilkhahn

## 238/10 – 238/13

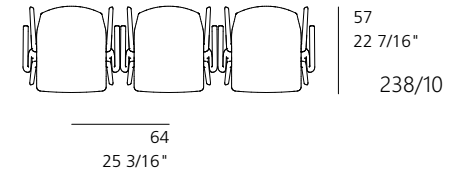
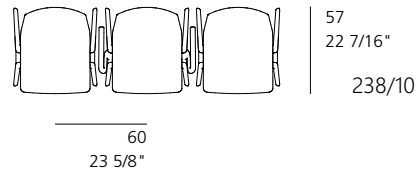
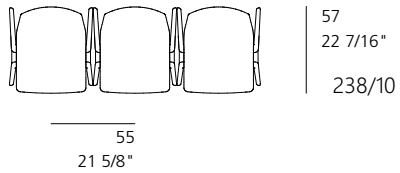
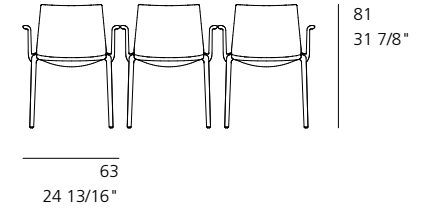
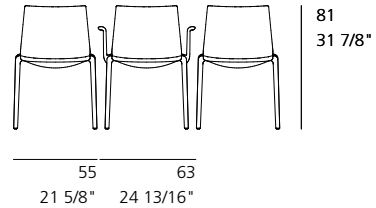
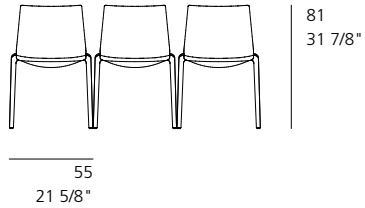

## 238/20 – 238/22

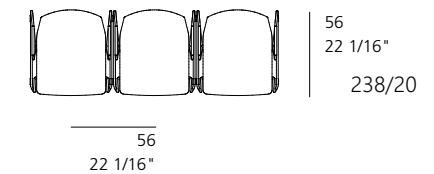
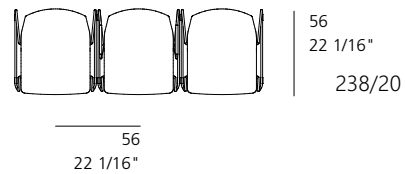
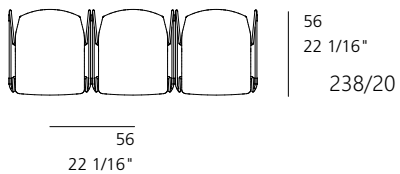
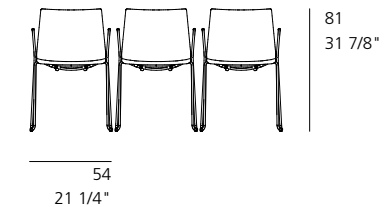
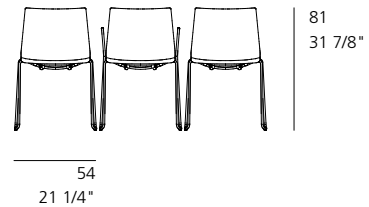
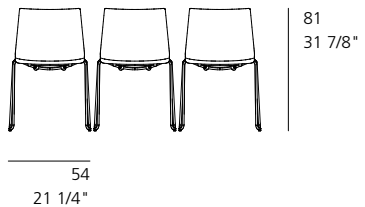



# Aula. 238 range. Models and dimensions.

# Wilkhahn

238/30 – 238/31

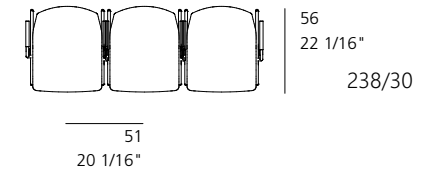
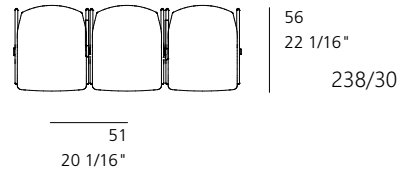
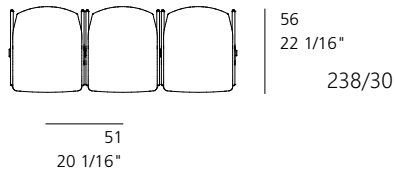
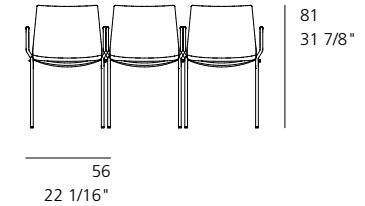
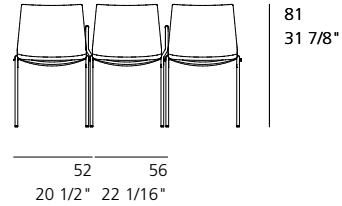
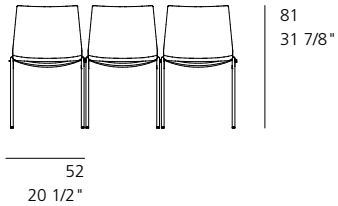

# Aula. 238 range. Technical details.

# Wilkhahn

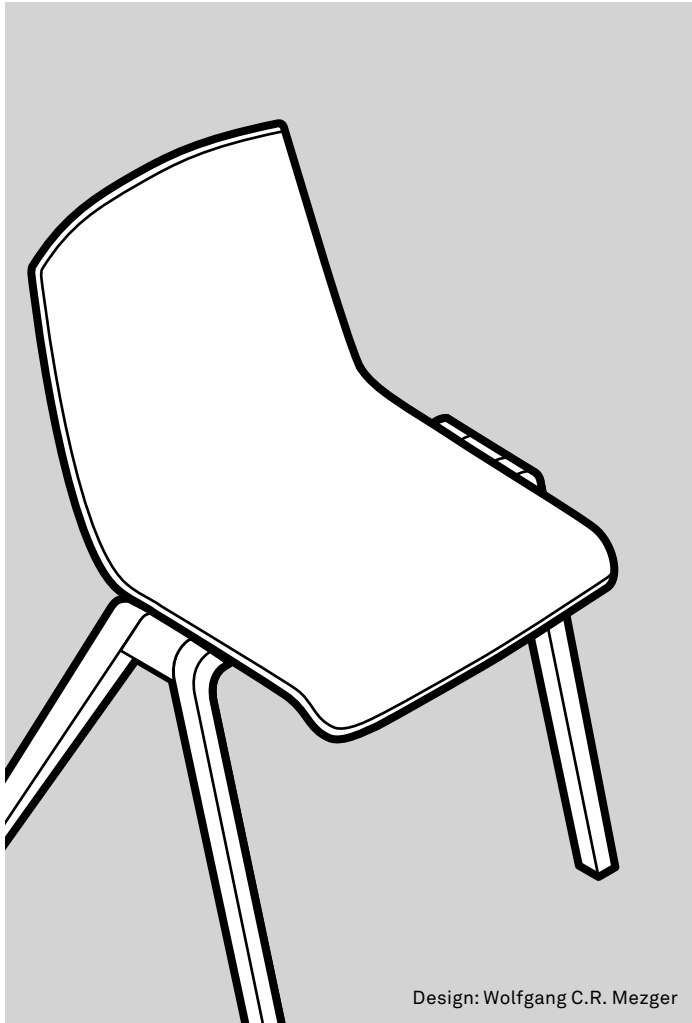

Design: Wolfgang C.R. Mezger

## Function

A lightweight, stackable multi-purpose chair with plastic frames and bright chrome-plated steel frames. Because of the shape, elasticity and ergonomic design of the seat shell, Aula is very comfortable to sit on for long periods of time. Six colors (with blue and orange are on request), four types of upholstery and three types of frame open up a broad range of furnishing and design options for congress and multipurpose spaces, meeting areas, company restaurants, seminar or conference centers, or co-working spaces.

## Frame/armrests

**Models 238/10, 238/11, 238/12 with a stackable, all-plastic frame** made of through-dyed, fiberglass-reinforced Ultramid, in white, black, gray, gray-beige to match the seat shell and on request (at an extra charge) blue-gray and orange-red, with multipurpose glides, optionally with felt glides, optionally with or without armrests in the same material and color, retrofittable on request.

**Models 238/20, 238/21, 238/22 with skid base made of tubular steel** (Ø 12 mm (4 9/8")), bright chrome-plated (stackable) or textured matt finish coated as far as possible to color-match the shell (not stackable) in white, black, gray, gray-beige as well as on request (for an extra charge) in blue-gray and orange-red, with multipurpose glides optionally with extra felt inserts, optionally with or without armrests in the same material and color. PVC-free, tube-shaped armrest pad made of black-gray, thermoplastic elastomer. Armrests not retrofittable.

## Models 238/30, 238/31, 238/32 with tubular steel four-leg frame

(Ø 18 mm (7 1/8")), bright chrome-plated (stackable) or textured matt finish coated to color match the shell as far as possible (not stackable) in white, black, gray, gray-beige as well as on request (for an extra charge) in blue-gray and orange-red, with integrated inline connector made of black, through-dyed, fiberglass-reinforced polyamide and multipurpose glides, optionally with extra felt inserts, optionally with or without armrests in the same material and color. PVC-free, tube-shaped armrest pad made of black-gray, thermoplastic elastomer. Armrests not retrofittable.

## Seat and backrest

Unitary, ergonomic molded seat shell made of through-dyed, fiberglass-reinforced polypropylene, similarly to the frame and armrests in white and black, gray, gray-beige as well as on request (for an extra charge) blue-gray and orange-red. Models 238/11, 238/21 and 238/31 with seat cushioning, models 238/12, 238/22 and 238/32 with padding on the inside (= unitary seat and back cushioning) each with replaceable upholstery panel made of plywood and breathable polyurethane foam. Model 238/13, with fully upholstered and covered plywood shell with unitary seat and back cushioning made of breathable polyurethane foam.



# Aula. 238 range. Technical details.

# Wilkhahn

## Accessories

Fixed inline connectors to link models with plastic frames (238/10, 238/11, 238/12), without armrests, made of zinc-plated steel, black zinc-plated (retrofittable). Adaptable, pull-out inline connectors to link up models with plastic frames (238/10, 238/11, 238/12), optionally without armrests, with and without armrests in combination with frames made of bent steel, black zinc-plated with clip made of fiberglass-reinforced polyamide in anthracite (retrofittable).

Inline connectors when a writing tablet is added on request.

Inline connectors to link models with skid bases (238/20, 238/21, 238/22), optionally without armrests, with armrests or in combination with frames with and without armrests in black, through-dyed polyamide.

Magnetic clip for seat and row numbering made of plastic in anthracite, can be slotted onto the frame on the right or the left (matches the frames in each case).

Number tags with white figures on anthracite sheet steel.

Writing tablet to slot onto the armrest (only when plastic frames are chosen), can be folded up, panel made of black HPL, plastic linking device in black (retrofittable). Chairs can still be stacked.

## Dimensions, weights

238/10, 238/11, 238/12, 238/13  
Seating height 45 cm (17 3/4"), total height 81 cm (31 7/8"), width without armrests 55 cm (21 5/8"), with armrests 63 cm (24 3/4"), depth 57 cm (22 1/2"), armrest height 67 cm (26 3/8").  
Center-to-center distances in linked rows, combination without/without armrests 55 cm (21 5/8"), with/without armrests 60 cm (23 5/8"), with/with armrests 640 mm (25 1/4"). Weight (not upholstered): 6 kg (13.23 lbs) without armrests, 6.75 kg (14.88 lbs) with armrests

238/20, 238/21, 238/22  
Seating height 45 cm (17 3/4"), total height 81 cm (31 7/8"), width without and with armrests 54 cm (21 1/4"), depth 56 cm (22"), armrest height 67 cm (26 3/8")  
Center-to-center distances when linked regardless of combinations 56 cm (22")  
Weight (not upholstered): 7.15 kg (15.76 lbs) without armrests, 7.46 kg (16.45 lbs) with armrests

238/30, 238/31, 238/32  
Seating height 45 cm (17 3/4"), total height 81 cm (31 7/8"), width without armrests 52 cm (20 1/2"), with armrests 56 cm (22"), depth 56 cm (22"), armrest height 67 cm (26 3/8")  
Center-to-center distances in all combinations 51 cm (20 1/8")  
Weight (not upholstered): 7.15 kg (15.76 lbs) without armrests, 6.75 kg (14.88 lbs) with armrests

Maximum number of chairs that can be stacked:  
15 free-standing with plastic and tubular steel frame,  
10 with a skid base (not upholstered),  
10 on a four-wheeled trolley,  
Height between chairs when stacked:  
90 mm (3 1/2") with a plastic frame,  
37 mm/52 mm (1 5/8" / 20 1/2") with a skid base (not upholstered/upholstered), 55 mm (21 5/8") with a tubular steel frame.

## Standards

In compliance with the DIN EN 16139 office chair standard, 10 chairs can be stacked vertically.  
The ANSI/BIFMA X 5.1 standard is complied with.



## Information

Stacking the models with plastic frames can cause shine or pressure marks to form. Only the bright chrome-plated versions of models with metal frames can be stacked.

# Aula. 238 range. Awards / standards / certificates.

# Wilkhahn

## Awards

The awards are for the 238/10 – 238/13 range



## Product certificates / product standards



DIN EN 16139 ANSI/BIFMA X 5.1

## Company's certificates, memberships

